

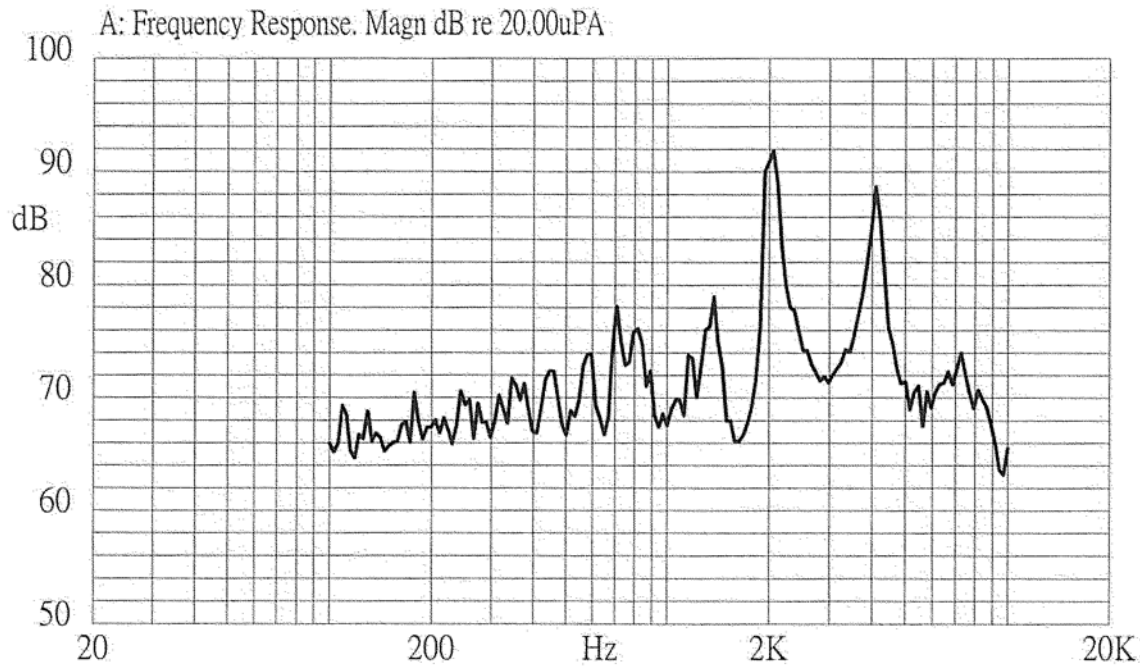
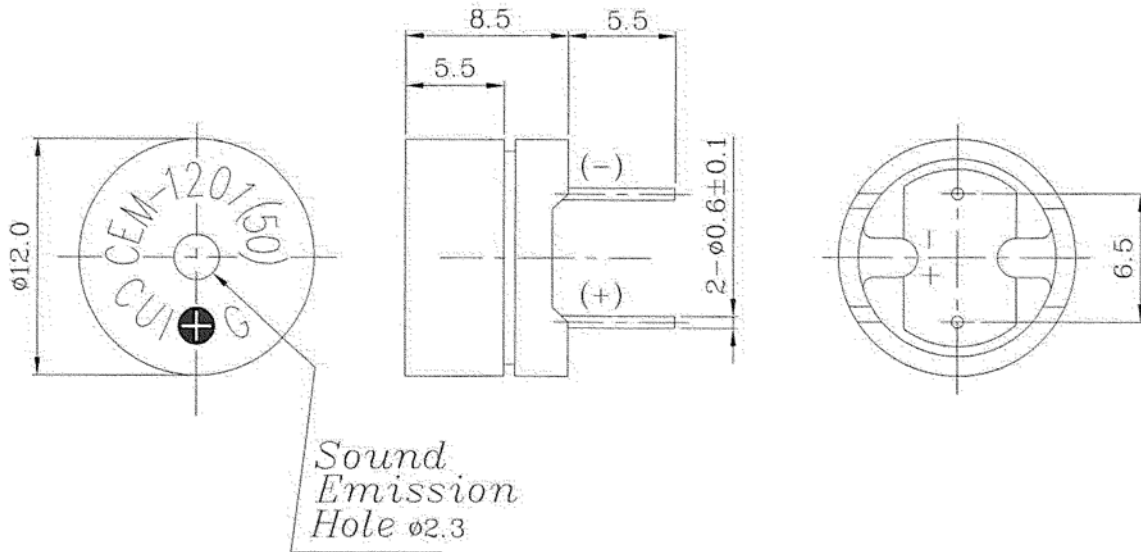
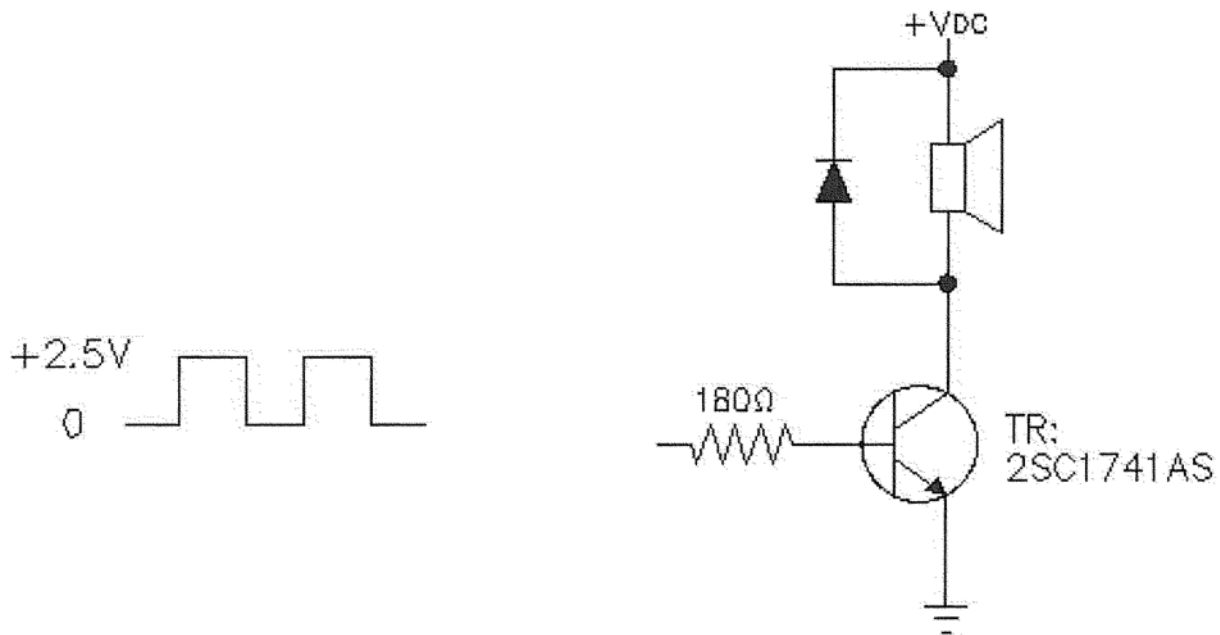

**Specifications**

Rated voltage	1.5 Vo-p	
Operating voltage	1.0 - 2.0 Vo-p	
Mean current	20 mA max.	
Coil resistance	50 ±7.5 Ω	Applying rated voltage, 2048 Hz square wave, ½ duty
Sound output	Min. 80 (Typical 87) dBA	Distance at 10cm (A-weight free air). Applying rated voltage of 2048 Hz, square wave, 1/2 duty.
Rated frequency	2,048 Hz	
Operating temperature	-20 ~ +60° C	
Storage temperature	-30 ~ +70° C	
Dimensions	ø12.0 x H8.5 mm	See attached drawing
Weight	1.4 g	
Material	PPO (Black)	
Terminal	Pin type (AU Plating)	See attached drawing
RoHS	yes	

**Frequency Response Curve**

**Appearance Drawing**

 Tolerance:  $\pm 0.5$ 

**Measurement Method**

**Mechanical Characteristics**

Item	Test Condition	Evaluation Standard
Solderability	Lead terminals are immersed in rosin for 5 seconds and then immersed in solder bath of $270 \pm 5^{\circ}\text{C}$ for $3 \pm 1$ seconds.	90% surface of lead terminals should be wet with solder. (Except the edge of the terminal)
Soldering Heat Resistance	Lead terminals are immersed up to 1.5mm from the buzzer's body in solder bath of $260 \pm 5^{\circ}\text{C}$ for $3 \pm 1$ seconds.	No in interference in operation.
Terminal Mechanical Strength	Apply force of 9.8 N (1.0 kg) in each axial direction for 10 seconds.	No damage or cutting off.
Vibration	The buzzer will be measured after applying a vibration amplitude of 1.52 mm (9.3G) with 10 to 55 Hz band of vibration frequency to each of the 3 perpendicular directions for 2 hours.	After the test, the part should meet specifications without any damage to the appearance and the SPL should be within $\pm 10\text{dBA}$ when compared to the initial SPL.
Drop Test	The part is to be dropped from a height of 75 cm onto a 40 mm thick wooden board 3 times in 3 axis (X, Y, Z) for a total of 9 drops.	

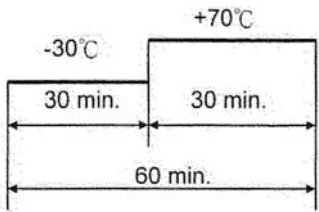
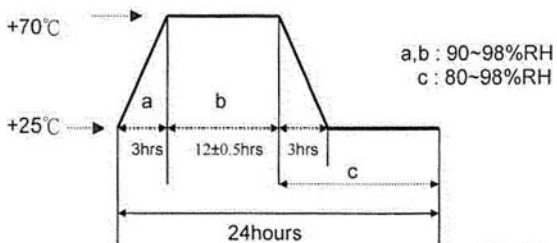
**Environment Test**

Item	Test Condition	Evaluation Standard
High temp. test	The part will be subjected to $+70^{\circ}\text{C}$ for 96 hours.	After the test, the part should meet specifications without any damage to the appearance and the SPL should be within $\pm 10\text{dBA}$ when compared to the initial SPL.
Low temp. test	The part will be subjected to $-30^{\circ}\text{C}$ for 96 hours	
Thermal shock	The part will be subjected to 10 cycles. One cycle will consist of: <div style="text-align: center;">  </div>	
Temp./Humidity cycle	The part shall be subjected to 10 cycles. One cycle will consist of: <div style="text-align: center;">  </div>	

**Mechanical Characteristics**

<b>Item</b>	<b>Test Condition</b>	<b>Evaluation Standard</b>
Operating (Life Test)	<p>1. Continuous life test: The part will be subjected to 72 hours at 45°C with 1.5 V, 2048 Hz applied.</p> <p>2. Intermittent life test: A dut cycle of 1 minute on, 1 minute off, a minimum of 10,000 times at room temperature (25 ±10°C) with 1.5 V, 2048 Hz applied.</p>	<p>After the test, the part shall meet specifications without any damage to the appearance. After 4 hours at +25°C, the SPL should be within ±10 dBA of the initial SPL.</p>

**Test Conditions**

Standard Test Condition	a) Temperature: +5 ~ +35°C	b) Humidity: 45 - 85%	c) Pressure: 860 - 1060 mbar
Judgement Test Condition	a) Temperature: +25±2°C	b) Humidity: 60 - 70%	c) Pressure: 860 - 1060 mbar



**Packaging**

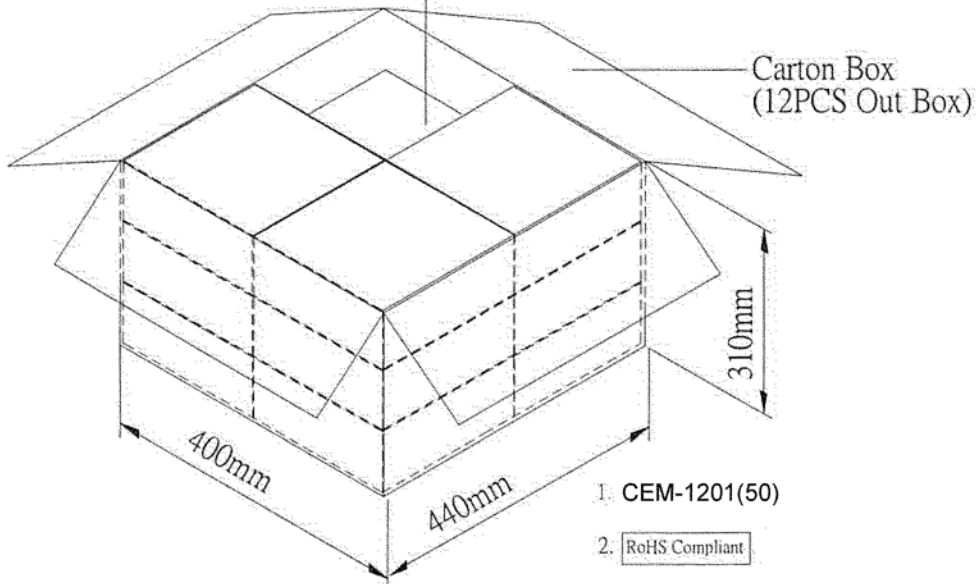
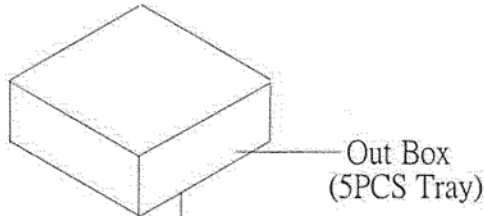
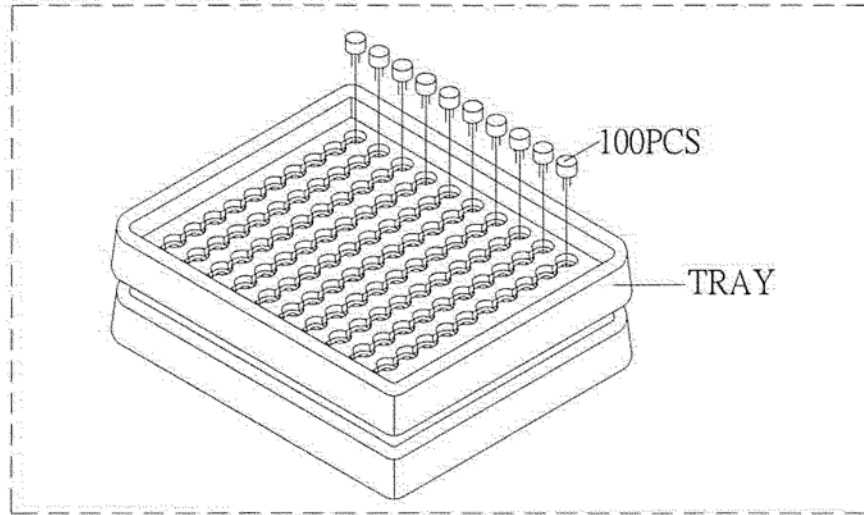

Tray	184mmx184mmx23mm	1x100PCS=100PCS
Out Box	200mmx190mmx100mm	5LAYERx100PCS=500PCS
Carton Box	440mmx400mmx310mm	500PCSx12=6000PCS